

## AUTOMATIC AIR AND GAS VENTS FOR LIQUID SYSTEMS AE30SS

### DESCRIPTION

The AE30SS all stainless steel sealed body air eliminator removes air from hot and superheated water systems and is also suitable for all liquids compatible with the construction, providing that their specific weight is not less than 0,75 kg/dm<sup>3</sup>.

This ball float type automatic air eliminator can be used in combination with other air elimination and separation systems or directly applied at high points in the piping.

### MAIN FEATURES

Corrosion resistant.

USE: Cold, hot and superheated water systems.

### AVAILABLE

MODELS: AE30SS – stainless steel.

SIZES: 1/2" and 3/4".

CONNECTIONS: Female threaded ISO 7 Rp or NPT.  
1/2" or 3/4" vertical Inlet.  
1/2" vertical outlet.

INSTALLATION: Vertical installation. It must be installed absolutely vertically at the points in the plant where the air tends to collect. The drain should be piped to a safe position.  
See IMI – Installation and maintenance instructions.

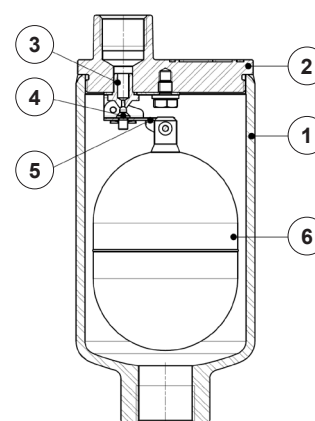
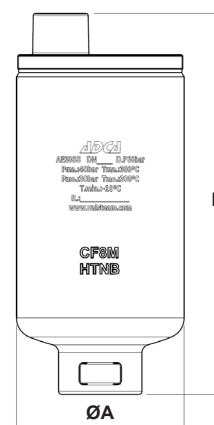

APPLICATION LIMITS	
Min. liquid specific weight	0,75 kg/dm <sup>3</sup>
Maximum working diff. pressure	30 bar

DIMENSIONS (mm)			
SIZE	ØA	B	WEIGHT (kg)
1/2"	80,5	187	2
3/4"	80,5	187	2

BODY LIMITING CONDITIONS	
THREADED PN 40	RELATED
ALLOW. PRESS.	TEMP.
40 bar	100 °C
33,7 bar	200 °C
31,8 bar	250 °C
29,7 bar	300 °C

MATERIALS		
POS.	DESIGNATION	MATERIAL
1	Body	A351 CF8M / 1.4408
2	Cover	A351 CF8M / 1.4408
3	Seat	AISI 316 / 1.4401
4	Valve	AISI 316 / 1.4401
5	Lever	AISI 304 / 1.4301
6	Float	AISI 316 / 1.4401

PMO – Max. operating press.: 30 bar.  
TMO – Max. operating temp.: 300 °C.

FLOW RATE CAPACITY (NL/min)																			
MODEL	SIZE	DIFFERENTIAL PRESSURE (bar)																	
		0,5	1	2	3	4	5	6	7	8	9	10	12	15	18	20	22	25	30
AE30SS	1/2" – 3/4"	31	46	72	96	120	144	168	192	216	241	265	313	385	457	505	553	626	746

Values shown refer to capacities of air discharge at 15 °C, under average atmospheric pressure (1013 mbar).  
If the temperature of the air differs from 15 °C, the discharge capacity can be corrected by multiplying it by:  $\frac{288}{273 + T}$ , where T is the actual temperature in °C.

It may be assumed that the temperature of the air is equal to the temperature of the water.